



## Low-cost and efficient fault detection and protection system for distribution transformer

Buhari Ugbede Umar<sup>\*1</sup>, James Garba Ambafi<sup>2</sup>, Olayemi Mikail Olaniyi<sup>3</sup>, James Agajo<sup>4</sup>, Omeiza Rabi Isah<sup>5</sup>  
School of Electrical Engineering and Technology, Department of Computer Engineering, Federal University of Technology Minna, Nigeria<sup>1,2,3,4,5</sup>

### Article Info

#### Keywords:

Distribution Transformer, Microcontroller, Fault detection, System Protection, GSM

#### Article history:

Received 30 October 2019

Revised 28 December 2019

Accepted 17 January 2020

Published 12 February 2020

#### Cite:

Umar, B., Ambafi, J., Olaniyi, O., Agajo, J., & Isah, O. (2020). Low-cost and Efficient Fault Detection and Protection System for Distribution Transformer. Kinetik: Game Technology, Information System, Computer Network, Computing, Electronics, and Control, 5(1), 79-86.  
doi:<https://doi.org/10.22219/kinetik.v5i1.987>

\*Corresponding author.

Buhari Ugbede Umar

E-mail address:

buhariumar@futminna.edu.org

### Abstract

*Distribution transformers are a vital component of electrical power transmission and distribution system. Frequent Monitoring transformers faults before it occurs can help prevent transformer faults which are expensive to repair and result in a loss of energy and services. The present method of the routine manual check of transformer parameters by the electricity board has proven to be less effective. This research aims to develop a low-cost protection system for the distribution transformer making it safer with improved reliability of service to the users. Therefore, this research work investigated transformer fault types and developed a microcontroller-based system for transformer fault detection and protection system using GSM (the Global System of Mobile Communication) technology for fault reporting. The developed prototype system was tested using voltage, current and temperature, which gave a threshold voltage higher than 220 volts to be overvoltage, a load higher than 200 watts to be overload and temperature greater than 39 degrees Celsius to be over temperature was measured. From the results, there was timely detection of transformer faults of the system, the transformer protection circuits were fully functional, and fault reporting was achieved using the GSM device. Overall, 99% accuracy was achieved. The system can thus be recommended for use by the Electricity Distribution Companies to protect distribution transformers for optimal performance, as the developed system makes the transformers more robust, and intelligent. Hence, a real-time distribution transformer fault monitoring and prevention system is achieved and the cost of transformer maintenance is reduced to an extent.*

## 1. Introduction

Distribution transformers are essential components and play an essential role in the electricity distribution system [1][2][3][4]. They are used to meet up ever-growing demand of electric energy by industries', household, and commercial activities. Uninterrupted power supply to the customer mainly depends on the working condition of the distribution transformer. Proper protection is needed for economic and safe operation in the electrical power distribution system. Distribution transformers can have a lifespan of 20 to 35 years of its design life, whereas, if properly maintained and operated under a good and rated condition, a transformer can have a useful lifespan of 60 years in practice [5][6][7][8][9][10]. The monitoring and controlling of distribution transformers are essential methods for detecting the quick alert of the electrical system, and also, for the proper performance of the electrical system [3]. The operation of the electric power system depends upon the effective functioning of the distribution transformer. As a result, monitoring and control of crucial variables like the voltage, current as well as temperature are necessary for assessing the performance of the distribution transformer and also help to minimize disruption due to sudden failure of the power system [11][12][13][14].

Currently, in Nigeria, the distribution transformers are monitored offline, mainly by the inspection officers from the utility company or the residents within the fault location who alerts the power company [15][16]. The practice encourages a slow response which often leads to power outages for a long time since the fault detection is not automated. The current method of manual monitoring and control (offline) of distribution transformer has the following shortcomings [12]: Operations of equipment failure are manually done; It takes much time; Much hard labour is required and Electricity customers and production process are affected enormously.

With the current advancement in technologies, especially in the area of telecommunication, it is easier to monitor distribution transformer in a real-time basis using any of the available technologies to report distribution transformer incidences, thereby improving their lifespan. Hence, prompt attention to distribution transformer faults is critical in power system which leads to avoiding harm and instability to the network. Distribution transformer monitoring and prevention system is proposed in this workpiece to overcome these challenges. Several existing systems have been deployed, but each has their respective limitations [17].

The remaining section of the paper is organized into four sections: section 2 provides a review of related works, the design methodology of the system is presented in section 3, section 4 provides results and discussions of the results. The conclusion is presented in section 5 and references in section 6.

## 2. Review of Related Works

Several kinds of literature reported works done in the area of the distribution transformer monitoring system with the aim of boosting the lifespan of the transformer and providing the uninterrupted power supply. Various types of system and technologies have been used for monitoring systems such as supervisory control and data acquiring (SCADA) system [16], radio frequency (RF) based control system [9], distributed control system [18], internet-based communication [9][19], WCDMA [20], GSM [9][21], ZIGBEE [22][16] and wireless sensor network (WSN) [23]. Some of these pieces of literature and the signs of progress made as well as the challenges currently being faced by the existing body of knowledge are reviewed in this section.

[22] Proposed a distribution transformer monitoring system using ZigBee technology and temperature sensors to monitor and report any transformer fault condition via the wireless ZigBee sensing network. However, the device had apparent limitations as the ZigBee module is short-ranged and cannot be employed to monitor dispersedly located area transformers. Secondly, it detects only a fault state and provides no solution. A similar remote transformer monitoring system was developed in [24] — using internet-based SCADA system for remote communication. But, was limited by heavy reliance on the availability of internet access, vulnerability to internet-based attacks, hackers and network threat. Also, in [10], a fault detection system using Bluetooth and Android application was developed. This method was quite effective but, the Bluetooth technology is short-ranged. On the other hand, a fault diagnosis system for power transformers using an artificial neural network (ANN) was developed by [25]. The system using ANN proved to be an efficient tool for classification and identification of the events. However, a substantial computational burden is inevitable for training or comparing signals [26]. Another transformer fault detection was developed using the wavelet transform in [27]. The developed system was an analytical approach to fault detection in transformer systems and the wavelet algorithm could detect a transformer fault quite accurately. However, it required high computational skill and expertise, it can only be used for fault detection of internal faults. Also, [28] developed a fault monitoring system using GSM technology and a modular software. The system used a novel distributed transformer remote monitoring software (DTRMS). The developed system was reliable, but it had no mechanism for transformer fault protection and control. Similarly, [29] developed an integrated system for health monitoring of power transformers with an auto-dialing unit. The developed monitoring system was designed using P89V51RD2 Microcontroller to monitor key parameters and communicates fault conditions to the operators, but its major limitation was the lack of a protection and control feature. [30] Developed a GSM-based condition monitoring system for transformers. The system monitors the transformer system and reported fault conditions such as overload, overvoltage and overheating (temperature). The developed system was mainly a reporting system, and it had no scheme for transformer protection. [31] Developed a microcontroller-based fault detection system using GSM. It was designed to monitor the condition of the distribution transformer at the Michael Okpara University of Agriculture Umudike. The system was quite efficient as a fault monitoring system, but it lacks a scheme for transformer protection and monitoring. [32], developed an RF-based distribution transformer monitoring system — it monitored and records key parameters of a distribution transformer such as load voltage, current load and oil temperature of the transformer. The system's RF provides low latency, which is good for a real-time communication system. Besides, the system is more of the monitoring system. It does not isolate the transformer when the problem arises; instead, it requires the effort of the operator to do so, which is time-consuming. Also, [33] proposed a mobile embedded system to monitor and record critical parameters such as the temperature of the transformer, oil level and load current. It reports in the form of SMS any abnormality via mobile phone of the operator. The system helps to detect the transformer fault and nothing more.

From the reviewed related kinds of literature and progresses made in transformer fault detection and protection system, it is observed that important steps have been achieved in transformer health monitoring, detection and protection system. Also, the microcontroller and GSM have played an essential role in transformer monitoring, detection and protection system. However, from the review, there is a need for a more improved system with high accuracy level for transformer fault detection, protection and reporting system. This research developed a reliable and low-cost transformer fault monitoring system by exploiting the application of the microcontroller-based system and GSM technology to transformer fault detection and prevention system.

## 3. System Design and Methodology

In this section, methods and application of the developed system are discussed. The essence of designing any transformer protection system is to develop a system that can efficiently handle any threat to transformer health such as overload, overvoltage and overheating (temperature). Our design is expected to yield a sustainable power supply to the customers and eventually, improve the lifespan of the distribution transformer. The developed system comprises of six units as shown in [Figure 1](#). The developed system was designed around a microcontroller Unit (AT89S52), which is

the processing unit. The microcontroller unit was interfaced with the GSM device alongside the sensing unit (sensors: voltage transformer, current transformer and LM 35) connected to the transformer. The system measures and reads the physical quantity from the transformer and then its analogue signal equivalent. Once the system is powered on, the voltage, current and temperature sensors detect the voltage, current and temperatures levels of the transformer. The digital output then feeds the microcontroller, and the microcontroller sends the output to the Liquid Crystal Display (LCD), displaying the appropriate message which is: the voltage, current and temperature level. The LCDs if there is any anomaly having compared it with the rated operating Level. These parameters are also fed to the GSM module of which it sends SMS to the operator indicating the transformer fault. The entire system is then interfaced with a control circuit (relay system and a DC Fan), a mechanism to protect the transformer system.

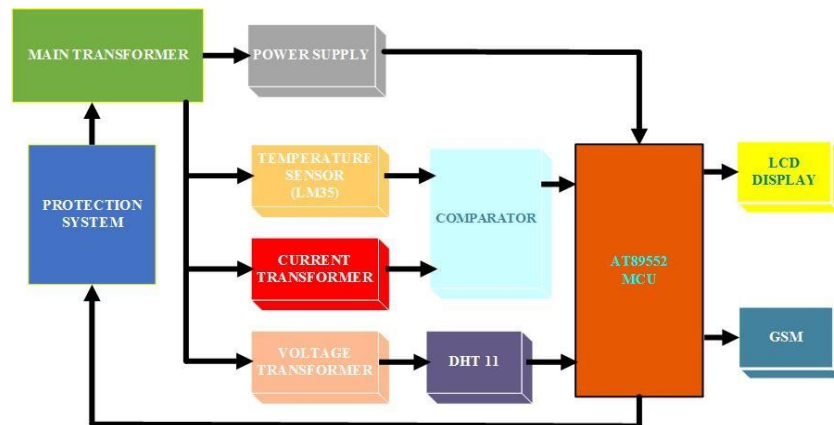

Figure 1. Block Diagram of a Transformer Fault Detection System

### 3.1 AT89S52 Microcontroller Sub-System

The microcontroller used for the system's implementation is Atmel's AT89S52. The microcontroller is a low-power, high-performance CMOS that is 8-bit with 8K bytes of in-system programmable flash memory. The device is manufactured using Atmel's high-density non-volatile memory technology and is compatible with the industry-standard 80C51 instruction set and pinout. The flash is on-chip, and it allows the program memory to be reprogrammed in-system or by a conventional non-volatile memory programmer. By combining a versatile 8-bit CPU with in-system programmable Flash on a monolithic chip, the Atmel AT89S52 is a powerful microcontroller which provides a highly-flexible and cost-effective solution to many embedded control applications.

### 3.2 Power Supply Unit

The power supply is the circuit from which the desired DC voltage to run the other circuits is obtained. Using 7805 we obtained 5V DC voltage. The power supply unit consists of five (5) critical components as shown in Figure 2. The components are: Transformer, Rectifier, Filter, Power Indicator and Voltage regulator – the voltage regulator is used in this work to maintain a constant output voltage level of 5V.

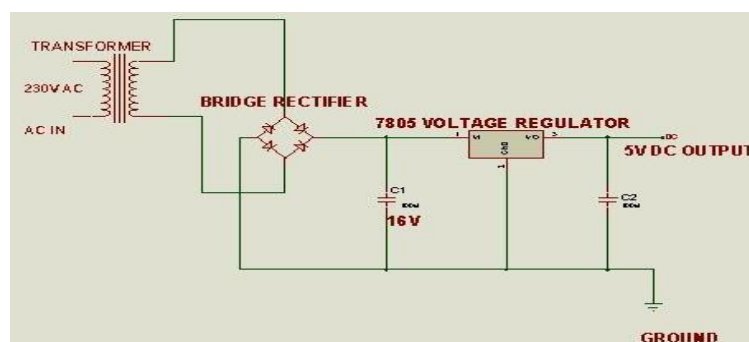

Figure 2. Circuit Diagram of Power Supply Unit

### 3.3 Relay system

The traits of a relay that makes it sensitive to low power operations necessitate its choice in this research. The relay in a real-time distribution system is designed to provide a proper shutdown of the system during any fault in the network. Figure 3, shows the relay used in this research.

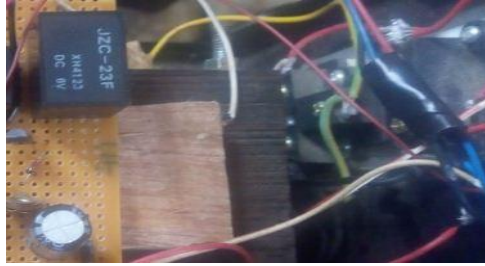

Figure 3. Relay

### 3.4 Software Implementation

The program code for the transformer fault monitoring system is written and compiled in the mikroC PRO which provides the instruction code for the AT89S62 Microcontroller. The mikroC PRO is a feature-rich development tool for AVR microcontrollers designed to offer the programmer the simplest solution for embedded systems application development without performance or control compromise. The mikroC PRO for AVR is user-friendly.

### 3.5 System Principle of Operation

The microcontroller unit anchors the system's mode of operation. Firstly, the system would be powered, from the mains, then the sensing unit scans the system to check if the transformer is working within rated conditions. Then the comparator alongside the Microcontroller unit, take the appropriate decisions, if the transformer is working within acceptable voltage, current and temperature levels, or in a fault state, an SMS is sent to the utility/operator board, and the protection system would isolate the detected fault. Figure 4 is a flowchart illustrating the system's principle of operation. The three-dimensional view of transformer fault detection and protection system are presented in Figure 5. and Figure 6. respectively, for a better understanding of the design concept and underlying principles of the system. The implemented working prototype is shown in Figure 7.

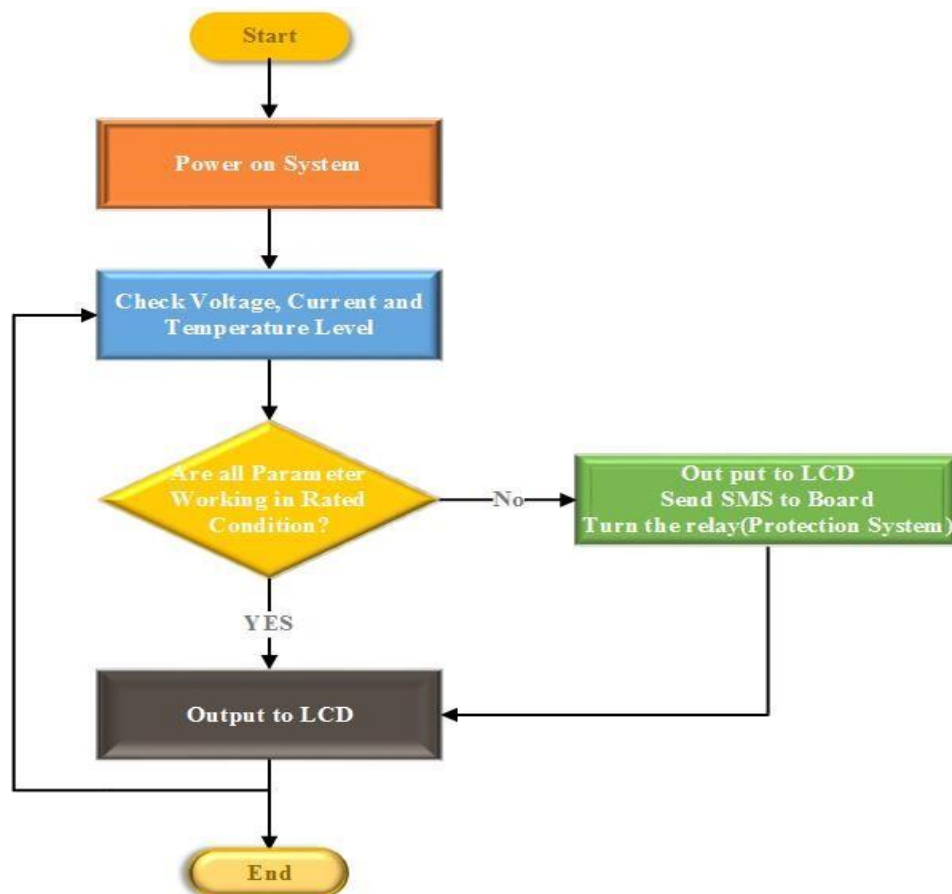

Figure 4. System Flowchart



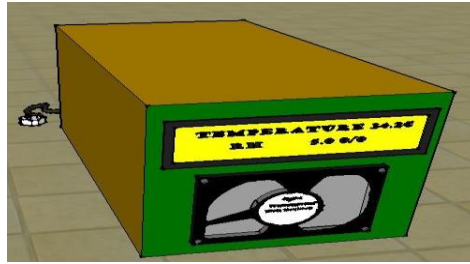

Figure 5. Front view of the system's 3D Model

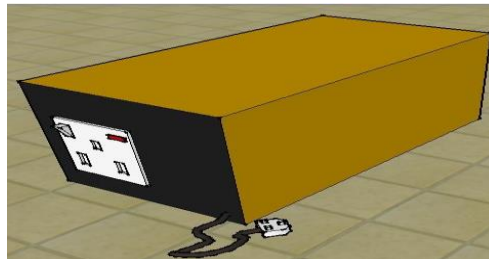

Figure 6. Rear view of the system's 3D Model



Figure 7. A Prototype of Transformer Fault Detection and Protection System

#### 4. Results and Discussion

This section presents implementation, discussion, analysis of the result and system evaluation of transformer fault detection and protection system using GSM technology for fault reporting. The entire system was first designed and simulated using Proteus (7.8) version. Figure 8, presents the implemented circuit diagram of the system. The system developed to consist of a microcontroller (Atmel's AT89S52) as the processor, a display unit, sensing unit, power supply unit, protection and control unit and a data communication unit.

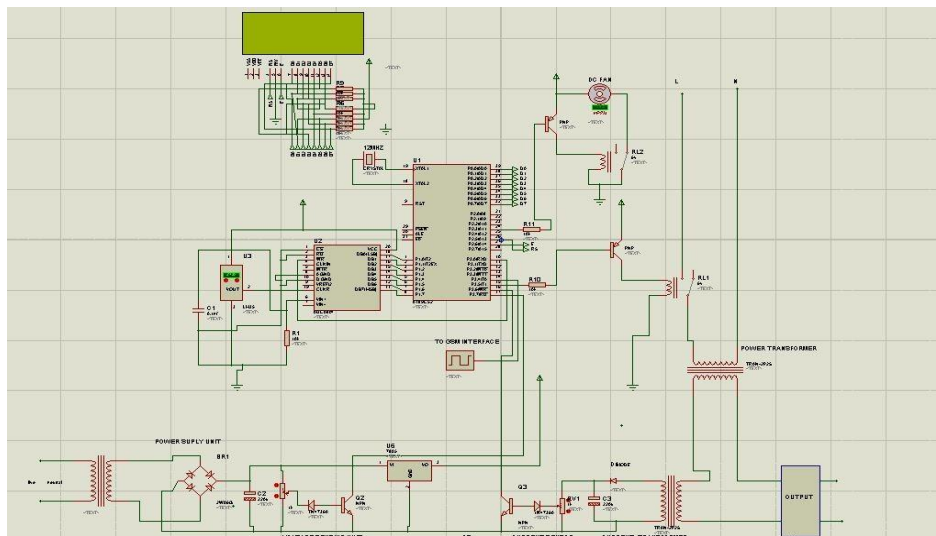

Figure 8. System Circuit Design

A 16×2 inches LCD was used to display the real-time temperature, overvoltage and overcurrent of the system as shown in Figure 9. Any change in the rating during the working of the system is displayed on the LCD, and the system simultaneously sends an SMS to the operator at a remote location, notifying him/her of transformer fault occurrence. Also, the relay circuit disconnects the transformer from the supply and activates its cooling system. The rating is based on the initial setting in the system as shown in Table 1.



Figure 7. Liquid Crystal Display Unit

Table 1. System State and System Response

Parameters	Range	System State	System Response
Voltage	>220 volts	Over-voltage	Disconnect Input
Load	>=200 Watts	Overload	Disconnect Output
Temperature	>39oC	Overheating	Turn on the Cooling System

The developed system was tested using electric bulbs of varying wattage; from 15 watts to 200 watts. The Input voltage from the mains was taken to be a constant 220V. The current and temperature levels vary (increases) as the load increases as shown in Table 2.

Table 2. Developed System Testing Results

S/No.	Load (Watts)	Voltage (Volts)	Temperature (°C)	Current (mamps)
1.	15	220	34.45	64.1
2.	25	220	34.68	109.6
3.	60	220	35.01	268.2
4.	120	220	35.82	536.7
5.	200	220	36.23	898.3

The system was able to carry out fault detection based on the stated threshold in the microcontroller unit as presented in Table 1. The system protection is carried out via the relay circuit, cooling system, and the transformer fault reporting using the GSM device. The protection and control were done to protect the system from current overload, overheating and over-voltage. The cooling system serves as a cooling mechanism for the transformer fault detection system.

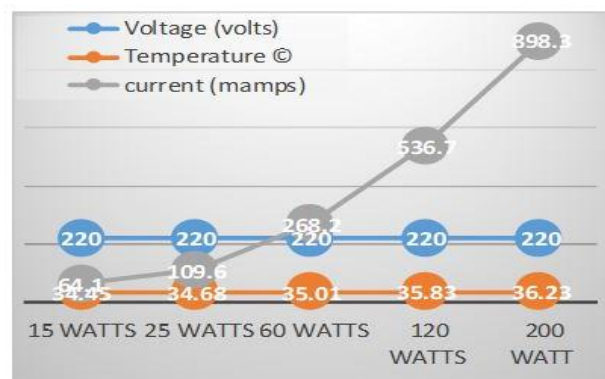

Figure 8. Graph of Load, Voltage, Current and Temperature

Figure 10 presents the results obtained from the testing of the prototype. The obtained results show a proportional relationship between load and temperature, as an increase in load leads to an increase in the transformer temperature. At a constant supply voltage of 220 volts, it is observed that by varying the load from 15 watts to 200 watts, the transformer current measured in milliamps also increases. The System protection scheme presented in Table 2. The system is expected to have a constant output of 220V AC. It would continue its normal operation as long as the input voltage from the mains does not exceed 220 volts. When there is a fluctuation above the declared operating voltage the system's protection mechanism would be turned on, i.e. the relay circuit would cut off the input power supply to the transformer, as shown in Figure 10. The developed system is to be operated within specific loads. The system was tested with five loads (electric bulbs of varying watts); 15, 25, 60, 120, 200 watts. The system was programmed to alert the operators of an overload at a load  $\geq 200$  watts. At this point, the system's response is to cut-off the transformer output. Table 2, shows the relationship between transformer voltage, load current, and temperature. An increase in temperature (heat) is experienced as the loading of the transformer increases. This relationship exists in a directly proportional manner.

The developed system was designed to operate within temperatures  $\leq 39^{\circ}\text{C}$ ; hence temperatures  $\geq 39^{\circ}\text{C}$  represent over-temperature. The proposed transformer fault detection system's performance was evaluated to ensure that the system meets its design objectives and that it performs more reliably. Hence, accuracy metrics were employed to measure the performance and reliability of the system. To check for the accuracy of the developed system, we compared the difference between the computed numerical values and the values obtained from system testing. The relationship between power, voltage and current is used for the comparison. Hence system accuracy is determined using the power Equation 1 and Equation 2.

$$P = VI \quad (1)$$

$$I = P/V \quad (2)$$

Using (2) the computation is as follows:

1. For 15 Watts; the True Value  $I_t = 15/220 = 0.6818$ ; the Measured Value  $I_M = 0.0641$ ,  $I_t - I_M = 0.004$  representing 99.6%
2. For 25 Watts; the True Value  $I_t = 25/220 = 0.1136$ ; the Measured Value  $I_M = 0.1096$ ,  $I_t - I_M = 0.0038$  representing 99.62%
3. For 60 Watts; the True Value  $I_t = 60/220 = 0.2727$ ; the Measured Value  $I_M = 0.2682$ ,  $I_t - I_M = 0.0045$  representing 99.65%
4. For 120 Watts; the True Value  $I_t = 120/220 = 0.5454$ ; the Measured Value  $I_M = 0.5367$ ,  $I_t - I_M = 0.0087$  representing 99.13%
5. For 200 Watts; the True Value  $I_t = 200/220 = 0.9090$ ; the Measured Value  $I_M = 0.8983$ ,  $I_t - I_M = 0.0107$  representing 98.93%

The variance between the exact and measured values increases with an increase in load. Hence the system exhibits high accuracy and an overall 99% accuracy at different loads' variation. In comparison with other cited work: [4][5][6][7][9][13][15][21][26][30][32][33], this research work outperforms them with isolating the system when faults occurs with a high system accuracy of 99%. The system makes distribution transformer more robust, secure and intelligent. With the system, a real-time distribution transformer fault monitoring and prevention system are achieved which adequately contained the cost of maintenance to an extent.

## 5. Conclusion

This research developed a microcontroller-based transformer fault detection and protection system using GSM technology for fault reporting. The developed system was evaluated against the set objectives: over voltage, temperature and overcurrent. The system was found effective and efficient. During abnormal conditions exceeding specified limits of temperature, voltage and current, the relay immediately isolates the transformer from the power line and communicate faults through GSM technology to the operators or the electricity board. The system can thus be adapted for use by Electricity Distribution Company to protect distribution transformer for optimal performance, reduced mean downtime of transformer thereby, increasing reliability and decreasing operations cost of the power system. The

system makes distribution transformer more robust, secure and intelligent. With the system, a real-time distribution transformer fault monitoring and prevention system are achieved which adequately contained the cost of maintenance to an extent.

## References

- [1] S. P. Aradhana Saket, A.K. Sharma, "Experimental Study and performance analysis of transformer cooling system," *International Journal for Research Trends and Innovation*, vol. Volume 3, No. Issue 9, Pp. 91 - 98, 2018.
- [2] R. A. Mohammad Riyaz, Sanjiv Kumar, "Analysis of Distribution Transformer Health Monitoring and Protection using Arduino," *International Journal of Innovative Research in Science, Engineering and Technology*, Vol. 7, No. 6, Pp. 7371 - 7377, 2018.
- [3] S. K. P, "A Survey on Different Technologies used in the Monitoring of Distribution Transformers in Power System," *International Journal of Engineering Development and Research* Vol. 6, No. 1, Pp. 175 - 179175, 2018.
- [4] F. B. Basil George, Vishnu Mohanan, Thomas George, "Remote Monitoring of Transformer using Microcontroller," *International Journal of Advanced Research in Electrical, Electronics and Instrumentation Engineering*, Vol. 6, No. 3, Pp. 1909-1914, 2017.
- [5] A. Bhakare Govind, P. Dabe Nilesh, and S. Pawar, "GSM Based Distribution Transformer Monitoring System."
- [6] V. P. Deepraj Duttachowdhury, Arya Parab, Raj Patel Karuna Nikum, "Transformer Monitoring and Control Using IoT," *International Conference on Innovative and Advanced Technologies in Engineering*, Vol. 10, Pp. 40-43, March 2018 2018.
- [7] D. K. R.V. Patil, Niranjan Hirugade, Arun More, Ashwinee and Kakade, "Transformer Health Monitoring And Control Through Arduino," *International Journal Of Electrical, Electronics And Data Communication*, vol. 5, no. 1, pp. 59 - 62, January 2017 2017.
- [8] D. N. P. Bhakare Govind A., Pawar S. D., "Gsm Based Distribution Transformer Monitoring System," *Ijarie*, Vol. 3, No. 3, Pp. 2324 - 2329, 2017.
- [9] R. T. Monitoring and C. O. Transformers, "S. Dharanya, M. Priyanka, R. Rubini and A. Umamakeswari," *Journal of Artificial Intelligence*, Vol. 6, No. 1, Pp. 33-42, 2013. <http://dx.doi.org/10.3923/jai.2013.33.42>
- [10] M. A. Nur, M. H. Sourav, M. Muhit, and M. K. Hossain, "Fault Analysis and Electrical Protection of Distribution Transformers," *Global Journal of Research In Engineering*, 2014.
- [11] J. Jayakumar, J. H. J. Queen, T. James, G. Hemalatha, and N. Lonappan, "Distribution Transformer Monitoring Using GPRS," *International Journal of Scientific & Engineering Research*, Vol. 4, No. 6, Pp. 1199-1204, 2013.
- [12] T. T. Vekara, S. Pettissalo, and N. Rajkumar, "Remote Monitoring System for Transformer Substations," in *NORPIE 2004*, 2004.
- [13] A.-R. Al-Ali, A. Khaliq, and M. Arshad, "GSM-based distribution transformer monitoring system," in *Electrotechnical Conference, 2004. MELECON 2004. Proceedings of the 12th IEEE Mediterranean*, 2004, Vol. 3, Pp. 999-1002: IEEE. <https://doi.org/10.1109/MELCON.2004.1348222>
- [14] M. Sarsamba, D. R. Yanamshetty, and P. Sangulagi, "The load monitoring and protection on electricity power lines using GSM network," *International Journal of Advanced Research in Computer Science and Software Engineering*, Vol. 3, No. 9, Pp. 1131-1136, 2013.
- [15] J. Egwaile and N. Bello, "Design and Implementation of GSM Based Transformer Phase Monitoring System," *Nigerian Journal of Technology*, Vol. 33, No. 3, Pp. 331-336, 2014. <http://dx.doi.org/10.4314/njt.v33i3.10>
- [16] P. Ravishankar Tularam Zanzad, Nikita Umare and Prof Gajanan Patle, "ZIGBEE Wireless Transformer Monitoring, Protection and Control System," *International Journal of Innovative Research in Computer and Communication Engineering (An ISO 3297: 2007 Certified Organization)*, Vol. 4, No. 2, Pp. 2395-4396, 2016.
- [17] K. O. Okokpujie, E. Amuta, R. Okonigene, and S. John, "Monitoring and Fault Detection System For Power Transmission Using GSM Technology," 2017.
- [18] Y. Y. Winn, H. M. Tun, and S. S. Y. Mon, "Design and Construction of Distributed Control System (DCS) Based Power Distribution in University Campus," *International Journal of Electronics and Computer Science Engineering*, Vol. 3, No. 3, 2012.
- [19] A. Sachan, "Microcontroller based substation monitoring and control system with gsm modem," *IOSR Journal of Electrical and Electronics Engineering*, Vol. 1, No. 6, Pp. 13-21, 2012. <https://doi.org/10.9790/1676-0161321>
- [20] B. Eyasu, "Design and Development of WCDMA-based Distribution Transformer Monitoring System," Thesis, Addis Ababa University, 2014.
- [21] H. J. S. M. Shabeer, A. Gnanesh, K. Vijaya and S. Praveen, "Implementation of A GSM Based Electrical Protection Scheme for Distribution Transformer Using Microcontroller," *International Journal of Advanced Research in Electrical, Electronics and Instrumentation Engineering*, Vol. 5, No. 53941 - 3944, 2016.
- [22] R. K. Pandey and D. Kumar, "Distributed transformer monitoring system based on ZigBee technology," *arXiv preprint arXiv:1403.3547*, 2014.
- [23] P. S. P. T. S. Somkuwar, M. G. Panjwani and N. A. Ghodichor, "Design and Implementation of Electrical Transmission Line Monitoring and Controlling System International Journal on Recent and Innovation Trends in Computing and Communication," Vol. 3, No. 74994-5000, 2015. <https://doi.org/10.17148/IJARCCCE.2015.4138>
- [24] S. Nunoo and E. K. Mahama, "Investigation into Remote Monitoring of Power Transformers using SCADA," *International Journal of Energy Engineering*, Vol. 3, No. 6, Pp. 213, 2013. <https://doi.org/10.5963/IJEE0306002>
- [25] E. Mohamed, A. Abdelaziz, and A. Mostafa, "Fault diagnosis system for power transformers," *Engineering Sciences*, Vol. 18, No. 2, 2007.
- [26] M. Anand, R. Sumi, G. Nithya, and B. Mahalakshmi, "Microcontroller Based Transformer Monitoring and Controlling System Using Zigbee."
- [27] Y. N. Sarem, E. Hashemzadeh, and M. Layegh, "Transformers fault detection using wavelet transform," *International Journal on technical and Physical Problems of Engineering (JTPE)*, Vol. 4, No. 10, Pp. 1, 2012.
- [28] A. Kumar, A. Raj, A. Kumar, S. Prasad, and B. Kumar, "Method for monitoring of distribution transformer," *Undergraduate Academic Research Journal (UARJ)*, ISSN, Pp. 2278-1129, 2012.
- [29] T. T. K. Gowri, Rajasaranya, "TRANSFORMER – An Integrated System for Health Monitoring of Power Transformers," *International Journal of Computer Science and Mobile Computing*, Vol. 2, No. 4105 – 110, 2013.
- [30] A. P. Monika Agarwal, "GSM Based Condition Monitoring of Transformer," *International Journal for Scientific Research & Development*, Vol. 1, No. 12, 2014.
- [31] I. C. Nweke Chisom B, Ogechikanmi Ihekweaba and Ifenkwe Clement E., "Using GSM to detect fault in microcontroller-based power transformer," *International Journal for Research in Applied Sciences and Engineering Technology*, Pp. 271-274, 2014.
- [32] R. Dhobale, A. Mahalle, A. Wankhede, K. Halmare, and M. P. Dixit, "Transformer Monitoring And Protection System Using AVR Atmega16 Microcontroller by RF Technology," 2018.
- [33] A. S. A. Hassan, "Monitoring and Controlling of Distribution Transformer Using GSM Module (AVR Microcontroller Based)," *International Journal of Advance Research in Science and Engineering*, Vol. 6, No. 8, Pp. 1645 - 1653, 2017.